

TABLE OF CONTENTS

SUBJECT	PAGE
The Burglary Threat.....	1 – 2
Outside Your Home	3
Closing Your Doors to Burglary.....	4 – 8
Hinge Doors	4
Sliding Glass Doors	6
Jalousie Doors.....	7
Double Doors	7
Garage Doors	8
Locking Out Trouble.....	9 – 12
Securing Your Windows.....	13
Double Hung Windows.....	13
Awning Type Windows	14
Sliding Glass Windows.....	14
Casement Windows	15
Jalousie Windows	15
Padlocks and Hasps.....	16
Operation Identification.....	17 – 18
Burglar Alarm Systems.....	20 – 21
Alarm Purchasing Guidelines	22
Homeowner Vacation Tips	23
Securing Your Apartment	24
Securing Your Mobile Home.....	25
The Neighborhood Awareness Concept	26 – 27
Suspect Identification Chart.....	28
Vehicle Description Reporting	29
Terminology When Reporting Crimes.....	29
Procedure for Reporting to Police.....	30

THE BURGLARY THREAT

When your home is burglarized, you lose more than just the radio, T.V., camera, silver or jewelry that you worked so hard to obtain. You also lose your peace of mind – and in some cases, you might jeopardize the safety and welfare of yourself and your family.

Residential burglary is a chronic nationwide problem that is growing in leaps and bounds. For its victims, it is as costly as well as a potentially dangerous crime which can lead to other crimes.

Fortunately, however, you can prevent burglary because in most cases it is a **crime of opportunity** – committed by young amateurs who are able to gain easy access to your home. You can eliminate the “opportunity” by making your home as difficult as possible for a burglar to enter and by making it less inviting to the potential criminal.

The time to take the necessary preventive steps to protect your home and family from burglary, though, is before you become a victim – not after the fact. All it takes is a modest investment of your time and not a great deal of money to employ the preventive measures recommended in this booklet and greatly minimize your chances of being burglarized.

Quality security hardware and other preventive measures will serve to deter, delay or help detect a burglar. It will stop the amateur burglar and slow up the experienced one, thus increasing his risk of being caught.

As the booklet explains, however, burglary prevention is much more than good locks and alarm systems. It is also being aware of daily habits that actually invite crime, suspicious persons and vehicles in your neighborhood (and reporting them to the police), and safe practices to follow like looking to see who is at your front door before opening it. It is being a good neighbor.

If you have home insurance, don't look at your policy as a burglary safeguard. It won't prevent burglary – and it will never fully replace the dollar value of your stolen articles because of depreciation and inflation. Needless to say, stolen family heirlooms and other articles of sentimental value are irreplaceable – and so is your feeling of well-being in your home.

The following pages will point out preventive measures you can take in your home, apartment or mobile home to greatly reduce your chances of becoming a victim of burglary and other related crimes. The sooner you put these preventive measures into effect, the safer your family, peace of mind and valuables will be. To really be effective, however, every member of your family must carry out the precautions on a daily basis.

Don't delay in providing your home and family the best protection you can give them. In Florida alone, hundreds of thousands of burglaries occur annually and millions of dollars worth of property are lost – of which a very small percentage is ever recovered and returned to its rightful owner. Don't gamble with your home and family – begin practicing crime prevention today!

OUTSIDE YOUR HOME

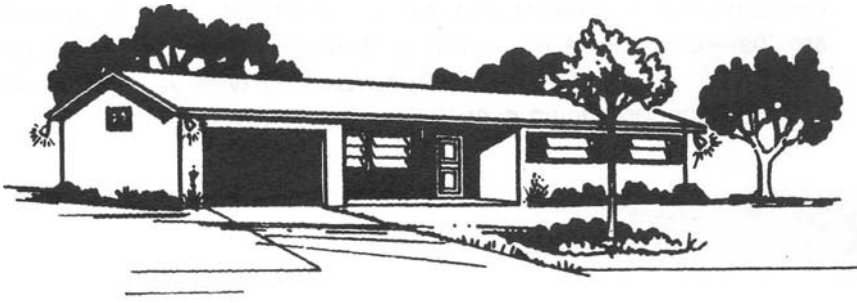

The exterior of your home should be free from offering concealment to a burglar. A house with doors and windows in full view is a psychological deterrent because an intruder is forced to work in the open where the risks detection. Here's how you can discourage a burglar:

- Keep shrubs trimmed away from windows and doors so you don't provide a convenient hiding place for a burglar.
- Maintain adequate exterior lighting, especially on vulnerable access points to your home. (Some power companies offer a bright security lamp and post at a nominal monthly charge)
- Don't leave ladders around the exterior of your house where they can be used by a burglar to gain entrance.
- Don't leave valuables such as lawnmowers, bicycles or tools to the yard or in an open or unlocked garage or shed. Your tools could be used to break into your home.
- Keep garage door closed and locked at all times. The door leading from the garage to the house is a favorite access point for a burglar.
- Display house number conspicuously and have it well illuminated. This will aid the police, medical or other emergency vehicles in finding your home quickly if summoned. Urge your neighbors to do the same—you may be calling for them or vice versa.

Never leave notes that can inform a burglar that your house is unoccupied.

CLOSING YOUR DOORS TO BURGLARY

1.

Hinge Doors

- The most common door type used in homes and apartments is the hinge door. It is important that all exterior doors be of solid wood core construction or that metal clad doors be used. Hollow core or composition board doors are not effective deterrents because they can be easily battered or bored. It is defeating the purpose of a good deadbolt lock to mount it on a hollow or foam core door.

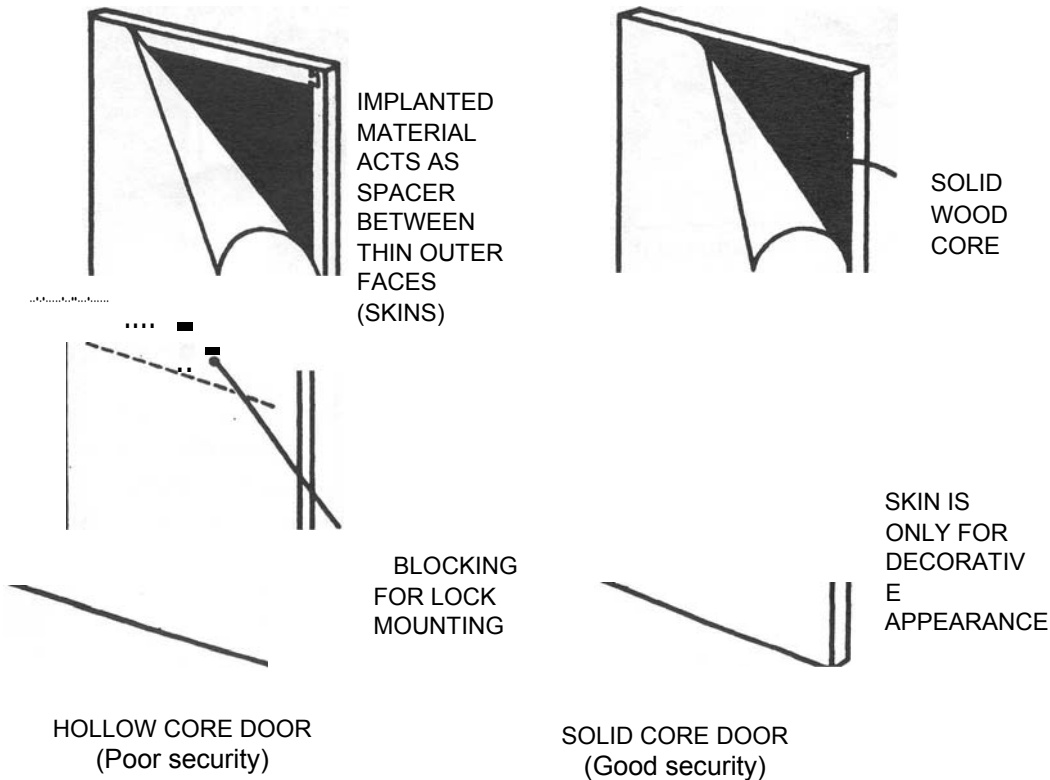

Lock all doors even when gone momentarily-down the street, to the store, visiting neighbors, etc.

4.

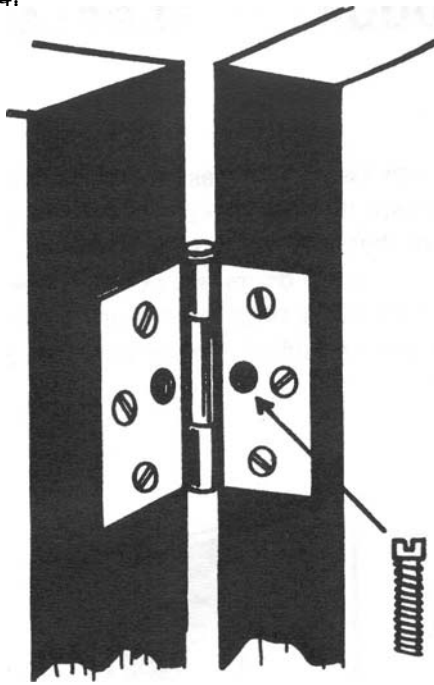

- If door hinges are exposed on the exterior of the door, non-removable hinge pins should be used. To prevent removal of a door that has removable hinge pins, you can employ a headless screw or nail. Drill two holes opposite each other in the center of both leaves of the hinge. Insert headless screw or nail into the leaf on the door frame side. Allow screw or nail to protrude $\frac{1}{2}$ ". When the door is closed, the screw will engage the other hinge leaf.

Drill a hole in the center of the hinge and insert a headless screw or nail in the door frame side, allowing it to protrude approximately one half inch.

- A solid wood core front door should have a wide angle viewer (180°) installed in it for easy viewing of visitors without opening the door. It is inexpensive and easy to install. Do not rely on a chain latch. **It is not a security device.**

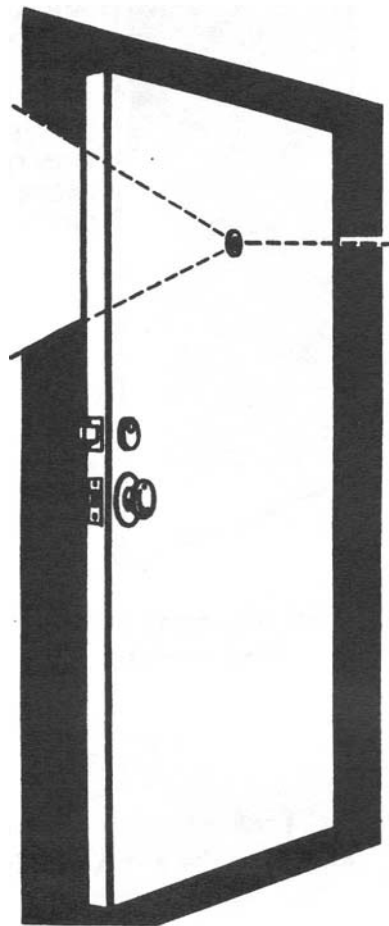

Sliding Glass Doors

Sliding glass doors are particularly easy targets for the burglar and are frequent points of entry. The locks they come equipped with can usually be quickly pried open. The doors can also be easily removed from their tracks unless they are properly secured.

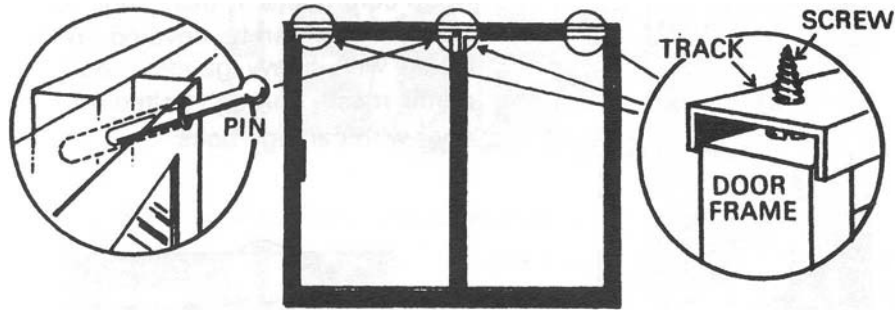

To prevent removal of doors, install 1 1/4" pan head (large head) sheet metal screws in upper track at both ends and the middle so frame just clears the head of the screws. To secure a door in position, you can also drill a hole at a downward angle in the overlapping frames of the door at the top center. Then insert a steel pin or a heavy nail.

6.

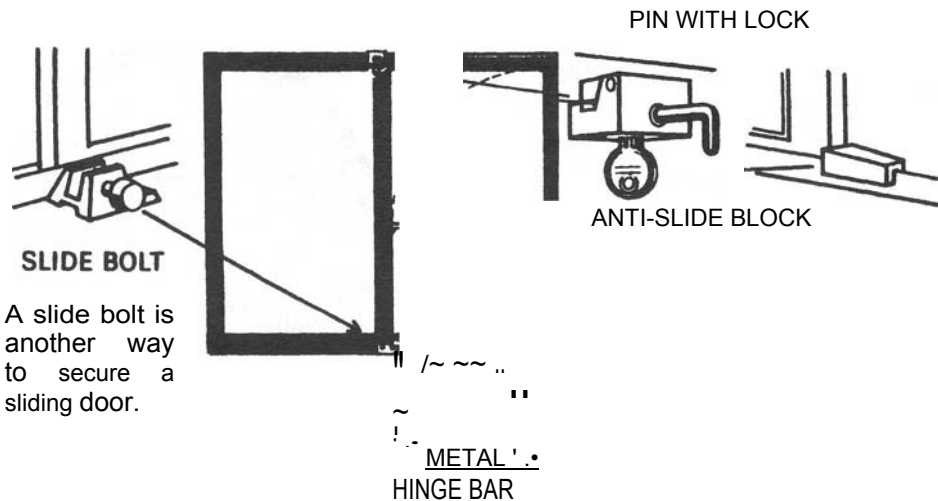

A slide bolt is another way to secure a sliding door.

- There are different types of sliding glass door auxiliary locks that can be used but key operated locks usually offer the best security-especially those using a deadbolt or pin mechanism.
- A metal bar that attaches to the side frame and fits across the middle of the sliding door, running parallel to the floor, can be used to prevent opening of the door.

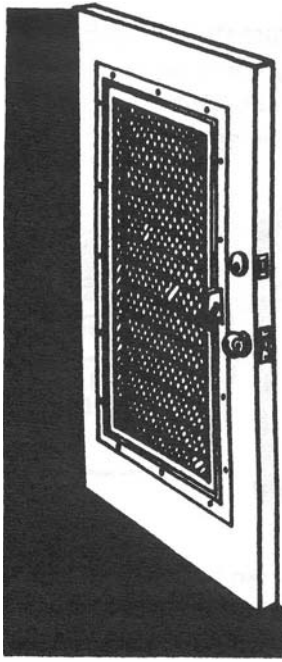

Jalousie Doors

Jalousie doors are a poor security risk because a burglar can easily gain entry through them. The best solution is to replace them with solid wood core doors. If this is not feasible, the door can be covered on the inside with heavy gauge expanded metal mesh, through-bolted to the door with carriage bolts.

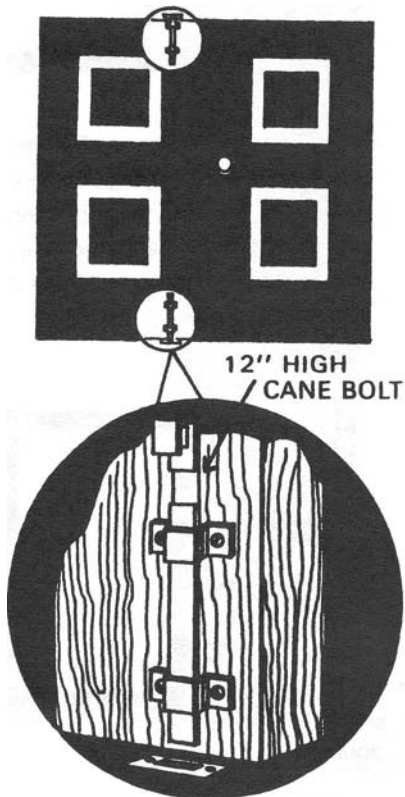

Double Doors

The inactive door can be adequately secured by installing cane bolts, $\frac{1}{2}$ " diameter x 12" long, on both top and bottom of door.

Lock the front door when working in the back yard and vice versa!

Garage Doors

- A good, case hardened padlock. on which both ends of the shackle engage, should secure your garage door. (See chapter on Padlocks and Hasps for illustration.)
- If the garage door rolls on tracks, a hole should be drilled in the track so that the padlock can be utilized as a brace. Steel pins can also be used.
- Electronic garage door openers with automatic locking devices offer good security.
- The door leading from a garage to the house should be a solid wood core door and should have a good quality deadbolt lock on it. This door is another favored access point for burglars because it offers concealment and access to your tools.

Keep your garage door and any doors leading from the garage to the house closed and locked-whether you are home or not.

LOCKING OUT TROUBLE

Sound locking devices cannot make e residence completely impregnable, but they can deter a burglar. They can force him into a situation in which he must break glass in order to enter-something he would probably like to avoid.

The amount of money spent on security hardware should be proportional to what is being protected. But by the same token, purchasing security hardware which meets the minimal technical requirements listed below could also protect your family from bodily injury. Since prices for security hardware vary depending on the area, the manufacturer and differences in cosmetic features, the buyer should "shop around."

- A chain latch on your door offers **no security at all**. Chain latches can be readily ripped off the door with minimum pressure. The best way to check a caller's identity is to use a wide angle viewer or peephole.
- A common type of lock in many homes and apartments is the key-in-knob or spring latch type. This particular lock is easily defeated by the most amateur burglar with a credit card or screwdriver inserted between the latch and the strike plate. This lock offers no security and should be supplemented by a single or double cylinder deadbolt lock or rim type or surface mounted lock. The dead latch is similar to the spring latch lock but has a small bar or plunger which will not permit opening with a shimming device. This is a poor security device since the plunger is very short and weak and should be supplemented by a quality deadbolt lock.



SPRING LATCH LOCK



DEAD LATCH LOCK

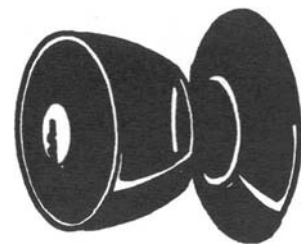

KEY-IN-KNOB

(These locks do not offer adequate security.)

- A single cylinder deadbolt lock should be mounted on a solid wood core door when there is no breakable glass within 40 inches of the interior locking mechanism. The single cylinder deadbolt lock has a thumb turn piece on the inside.

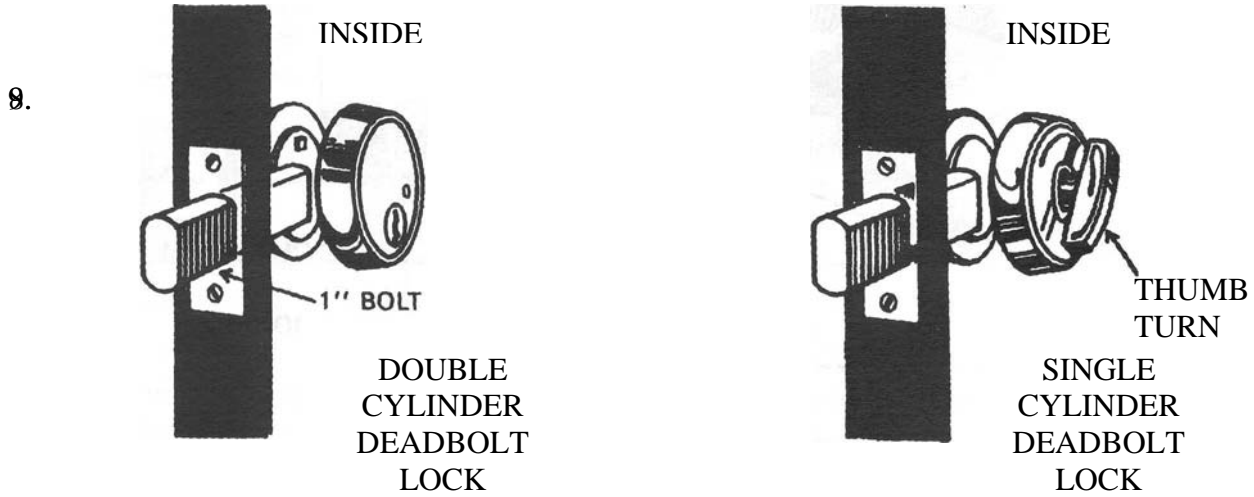

A double cylinder deadbolt lock, which is key operated from both the interior and exterior, should be used when there is glass within 40 inches of the interior locking mechanism. (**Caution:** The use of a double cylinder deadbolt lock can be a fire escape hazard. If this type of lock is used while the home is occupied, either leave a key in the lock or hanging somewhere near the lock. Children should be trained in the use of this lock and know the exact location of the key. When the dwelling is unattended, the key should be hanging out of the reach of a burglar who may break the glass.)

**When moving into a new dwelling, have tumblers in all exterior locks changed.
This can be done inexpensively by a licensed locksmith.**

- Both single and double cylinder deadbolt locks should meet these basic criteria to be a good security device:

10.

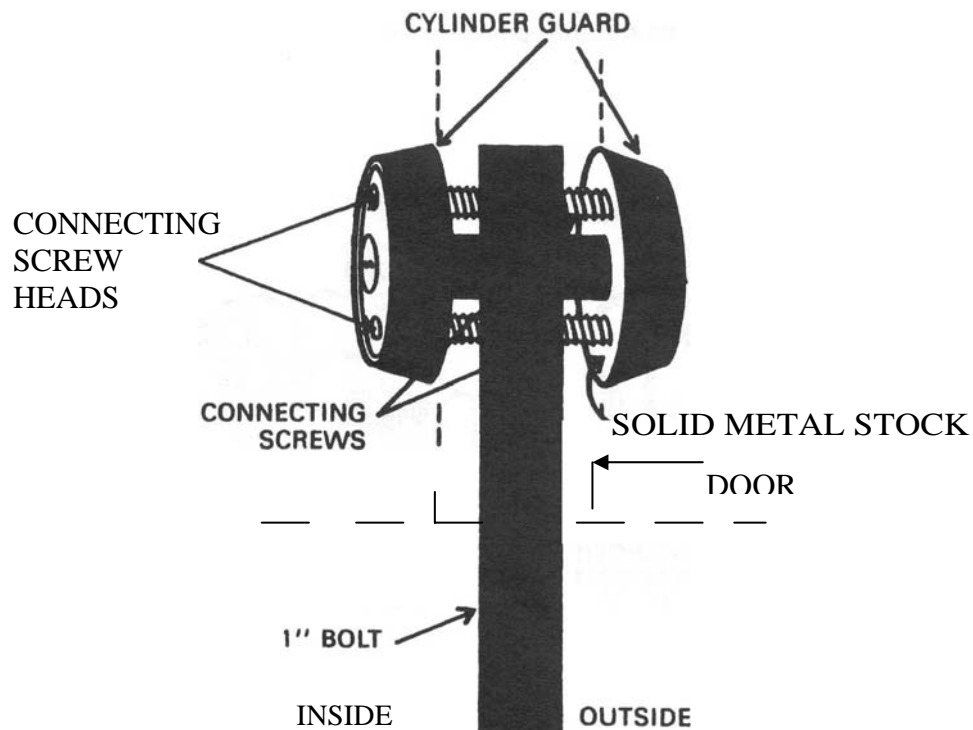

1. The bolt must extend a minimum of 1" and be case hardened or contain a hardened insert.
2. The cylinder guard must be tapered or spherical in design to make it difficult to grip with pliers or a wrench. It must be made of solid metal-not a hollow casting or stamped metal-and preferably be able to turn freely.
3. The connecting screws that hold the lock together must both be on the inside. There must be no exposed screw heads on the exterior of the door.
4. The connecting screws must be at least $\frac{1}{4}$ " in diameter and screw into solid metal stock-not screw posts.

When shopping for a deadbolt lock, you may wish to take the above diagram and description to a locksmith or hardware store to be sure the lock you buy meets all of the requirements.

Do not allow children to open the door to strangers!

- Rim type or surface locks use a vertical or horizontal deadbolt locking mechanism (see diagram). These locks are mounted on the interior surface of the door. A rim type lock is good security if it is the interlocking (jimmy resistant) type. This lock can only be used on doors that swing in.

Proper installation of this lock is extremely important. The strike should be secured to the door jam with minimum 2" wood screws. The lock must be through-bolted to the door with carriage bolts. Do not use wood screws to mount the lock.

MINIMUM 2" WOOD
SCREWS



STRIKE

CARRIAGE BOLTS

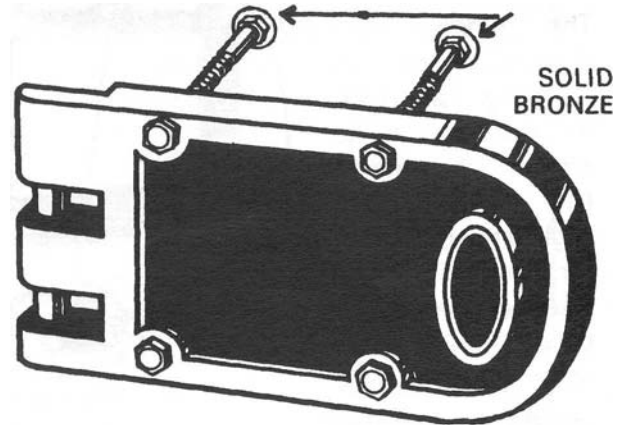

RIM TYPE OR SURFACE LOCK (JIMMY RESISTANT)

As a second line of defense, you may want to consider a security closet for storage of valuables which are kept in the home. This closet should be equipped with a solid wood core door with hinges with non-removable pins and a good quality deadbolt lock.

SECURING YOUR WINDOWS

Double Hung Windows

The latches on many double hung windows can be easily jimmied or pried open. This type of window can be simply and inexpensively made secure, however.

- The window can be pinned by drilling a hole at a slight downward angle through the first sash and into but not through the second sash. The window can then be pinned with a strong nail. Additional holes may be drilled for pinning the window in a slightly open position for ventilation.

DOUBLE HUNG WINDOW

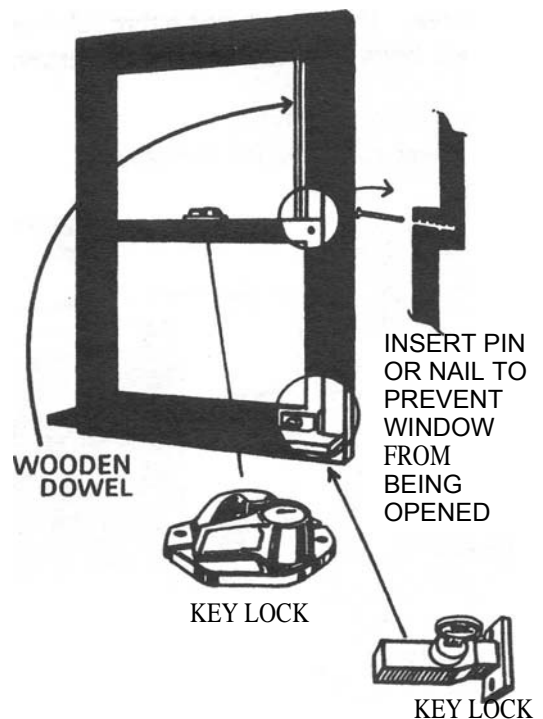

- Several types of keyed locks which offer effective protection are available for double hung windows. They are inexpensive and easy to install. But remember to master key all window locks for convenience and train children in their use.
- The thumb turn locks in the center of most double hung windows offer very little security
- A stick or wood dowel can be securely wedged between the top and bottom portions of the window. The stick can be secured to the inside of the window frame with pieces of hook and loop material. In this way, the stick can be shortened to allow for window ventilation.

Don't hide keys under a mat, over the doorsill-or anywhere outside!

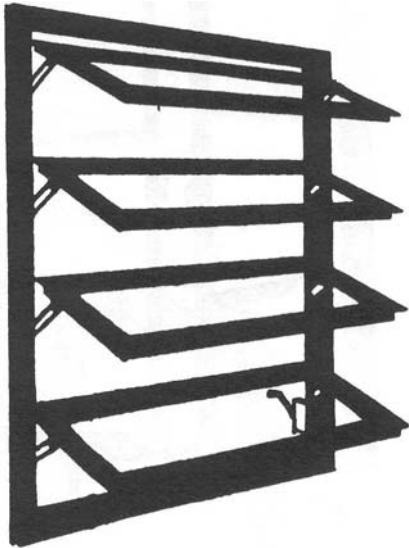

Awning Type Windows

Awning type windows are difficult to secure. The removal of the inside operator handle adds some security, but keep the handle handy in case of emergency. Awning windows should be tightly closed to enhance security

Sliding Glass Windows

Sliding glass windows can be secured in the same manner as sliding glass doors. Pins through the frame, screws in the track or keyed locks can all be used. Many inexpensive auxiliary locks are available.

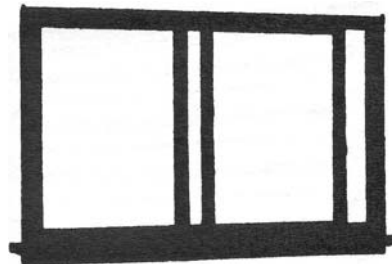

Require identification from all repair and delivery personnel. If in doubt, check the authenticity of the identification by calling the company before letting the person in your home. Check I.D. through the peephole viewer.

Casement Windows

Casement windows provide good security. Keyed locks are also available for this type window for additional security. Make sure the latch works properly and the operator handle has no excess play.

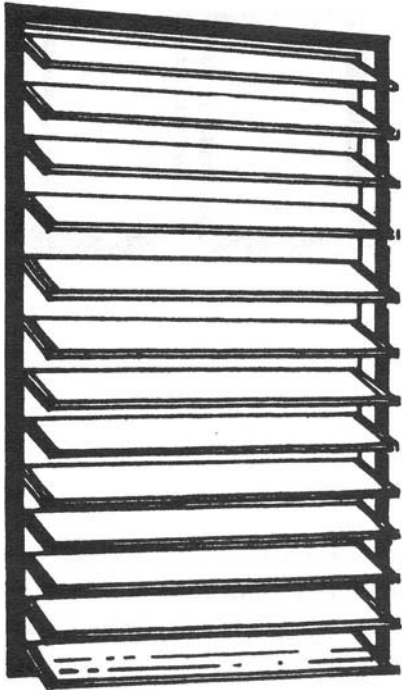
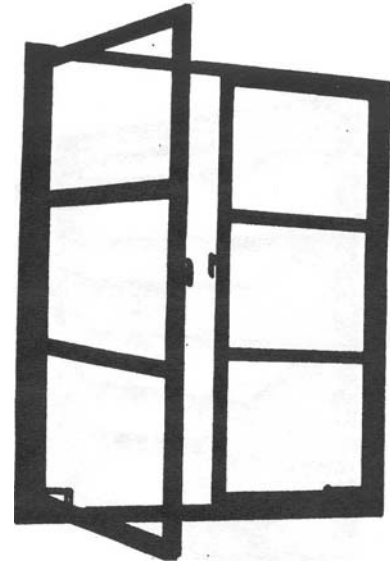

Jalousie Windows

Jalousie windows are a very high security risk and should be replaced if at all possible. They can be secured by installing metal grating on the inside of the window area with a quick release feature. In the event of fire. At a comparable cost to installing grating, the windows can be replaced with another type which offers better security.

PADLOCKS AND HASPS Padlocks

Padlocks should be of case hardened steel construction with a minimum 9/32" shackle. The lock should have a double locking mechanism on both the heel and toe of the shackle. It should be of heavy body construction with a minimum five pin tumbler.

13. MINIMUM 9/32" SHACKLE

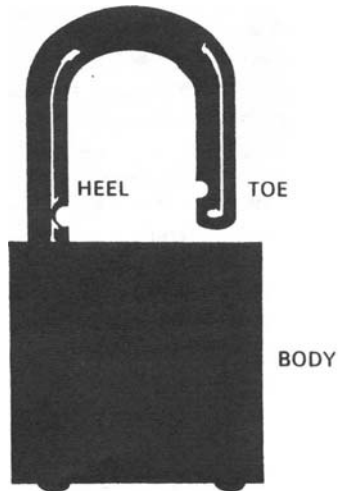

CASE HARDENED STEEL
PADLOCK

The bottom end of the padlock may have a key number stamped on it. This number should be obliterated and recorded elsewhere to eliminate the possibility of unauthorized key duplication.

Hasps

The hasp should be as strong as the lock and have no screws or bolts visible when secured. Screws which hold the hasp in place should be as long as the material holding them will allow. If installed on metal, carriage bolts with large washers should be used to prevent prying of the hasp.

HARDENED HASP

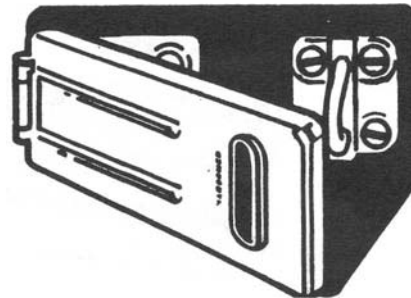

OPERATION IDENTIFICATION

Operation Identification is the engraving of your valuables with your Florida driver's license number to deter burglars and also to prove ownership should the article be stolen and recovered by the police. Permanently marked valuables are more difficult for the burglar to dispose of and many times he won't bother stealing these items

Do not mark valuables with your Social Security number. Federal regulations governing the identity of Social Security registrants make the numbers next to impossible to trace.

- Electric engravers or diamond tip pens are usually available from your local law enforcement agency or can be purchased inexpensively from a hardware store. You should mark your valuables FI followed by the 12 -digit alpha-numeric code number on your driver's license. If you are not a driver and are over 18 years of age, any Florida Driver's License Issuing Station will issue a Department of Motor Vehicles I.D. card. This I.D. card will have the same alpha-numeric code number for purposes of identification as a driver's license. This number can then be traced back to you in the event that marked stolen property is recovered by the police.
- Valuables that cannot be marked, such as antiques, silver, china, coins, etc should be photographed in detail with a complete description of the article on the back of the photograph.



- After you have marked your valuable property, display an Operation Identification sticker on all exterior doors to advertise the fact. This may act as a deterrent to a potential burglar. Stickers are available from your local law enforcement agency.
- Make sure you have a record of all marked valuables and their serial number, make, model and the location of your marking

- Make sure you have a record of all marked valuables and their serial number, make, model and the location of your marking

OPERATION IDENTIFICATION RECORD

IUGGISTID ITHII FDII •• AII KING: IicyeM, T.V.' •• _____
 -_ ,Hd Clfool -_ IIt, _
 ". _od vi •• YOU' Dr"" L_ Humlt. FL DL

AIITeLi

**MANUFACTURER
AND MODEL**

IIIIAL NUILEII

LOCATION
"AIKED

Report suspicious persons or activities in your neighborhood to the police. The police would rather check but out reports of a suspicious car or person than spend days and weeks following up on a burglary that could have been prevented! Remember, a burglar doesn't look like a burglar.

HOME SECURITY CHECKLIST

Yes No

- 1. Do exterior lights illuminate all entrances to your home?
- 2. Is shrubbery kept trimmed back so a burglar can't hide near windows and doors?
- 3. Are garage doors kept closed and locked at all times?
- 4. Are exterior doors made of solid core construction (including door leading from garage to house)?
- 5. Is there a peephole viewer (180°) on the front door?
- 6. Are sliding glass doors secured with auxiliary locks or pinned, and are screws in the track to prevent removal of doors?
- 7. Are exterior doors secured with a deadbolt lock (single or double cylinder) with a minimum 1" throw?
- 8. Are windows secured with auxiliary keyed locks or pinned with a nail?
- 9. Do you report suspicious persons or activity in the neighborhood to the police immediately?
- 10. Are doors locked at all times?
- 11. Are your valuables marked with your Florida driver's license number and do you have a record to them with complete serial number and make and model?

If you were able to answer yes to all of the above precautions, you have greatly decreased the likelihood of your home being burglarized

Check to see who is at the door before opening it to strangers. A wide angle viewer is easy to install and inexpensive.

BURGLAR ALARM SYSTEMS

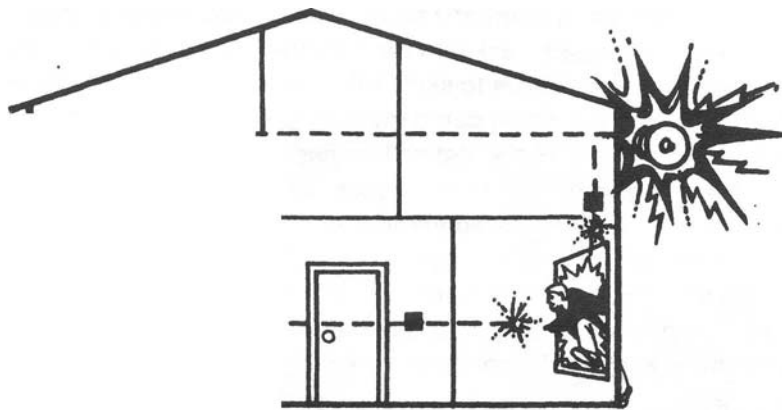

Some residential systems are designed to ring a bell and / or illuminate the area to scare off an intruder. These local systems send a signal from a sensory device directly to a light system or to a bell or siren located in your attic or on the outside of your home.

When a sensory device detects an intruder, the sounding device is activated and / or the house lights are turned on. It is hoped that the lights or sound will alert the homeowner (if at home), a neighbor or a cruising police unit. Since the typical residential burglar is not a professional, a local system will scare him from the premises.

Many companies will install a combination system which includes a local alarm (bell and / or lights) and a central reporting alarm. An advantage of having the central reporting system is that it is being constantly monitored by an alarm company. If the alarm goes off, the alarm company notifies the police department.

It is a good idea to have at least one smoke detector built into your alarm system. Smoke is the primary killer in fires and a smoke detector placed in a hallway between bedrooms can save lives.

Added protection is provided by a back-up power supply in the event of a power failure and a built-in ability to test the system regularly.

You get what you pay for. In this regard, be sure that the sensor devices (magnetic contacts, motion detectors, pressure mats, screens, etc.) to be installed are Underwriters Laboratories (UL) approved for burglary protection.

There are usually two costs involved when dealing with an alarm company: an installation charge and a monthly service charge. It is not recommended that you buy or lease a system from a company which does not offer a contract for continuing maintenance and service.

Once the alarm company representative has made an appraisal of your security needs, ask him for a written proposal and a copy of the contract you will have to sign. Take some time, look it over, think about it. Check the alarm company's reputation by calling the information department of the Better Business Bureau.

Never sign a contract which does not list all points of protection and does not itemize the equipment to be installed.

There are laws in some areas that prohibit anyone from having a device attached to their telephone that will automatically call the police or fire departments in an emergency situation. A system that calls a security company is legal and they in turn will notify the police.

Remember: A good alarm system is an investment in your security and personal well being. The mere presence of an alarm is often a deterrent. Advertise the fact that your premises are alarmed by using warning decals.

When going out for the evening make your house appear to be occupied by leaving lights on in different rooms and perhaps a radio playing. A bathroom is a good place to leave a light on.

ALARM PURCHASING GUIDELINES

When shopping for a burglary alarm system, use this guideline to check out the system you are considering as well as the dealer:

1. Is the company a local business? If so, how long have they been in business in your area?
2. Is the company a member of any local business organization?
3. Check with the local Consumer Affairs Office or Better Business Bureau to see if there have been any problems with this company.
4. What is the alarm background or the company's installation personnel?
5. Does the company offer 24-hour service in case of false alarms?
6. Will the company work with you in getting reduced insurance premiums if you install one of their systems?
7. Is there a warranty or maintenance contract for the system?
8. Is the system electrically or battery operated? If electrically operated, does it switch automatically to battery power without activating the alarm in the event of a power failure?
9. If the alarm system is activated, will it automatically shut off after a reasonable alert period (10-15 minutes)?
10. After the system is activated, will it automatically reset if attacked again?
11. If the control switch or box is exposed, will it activate the alert if attacked?
12. If it is a hardwire system (wires connecting sensor to control to alert), are the wires protected from attack and unnecessary wear by the elements?
13. If It IS a local system (audible in the immediate area), does it ring loud enough to attract the attention of your neighbors?
14. If the system is for a commercial premise, will the company have someone respond to the location in order to assist the police by opening the building?
15. Does the system have time delay, if appropriate, to activate and deactivate the alarm system without setting off the alert?
16. If the system is monitored by a central station, is it a tape recording or person? (In some municipalities, the call for assistance to the police cannot be made by a taped message.)
17. Is the system Underwriters Laboratories, Inc. (U.L.) approved?

HOMEOWNER VACATION TIPS

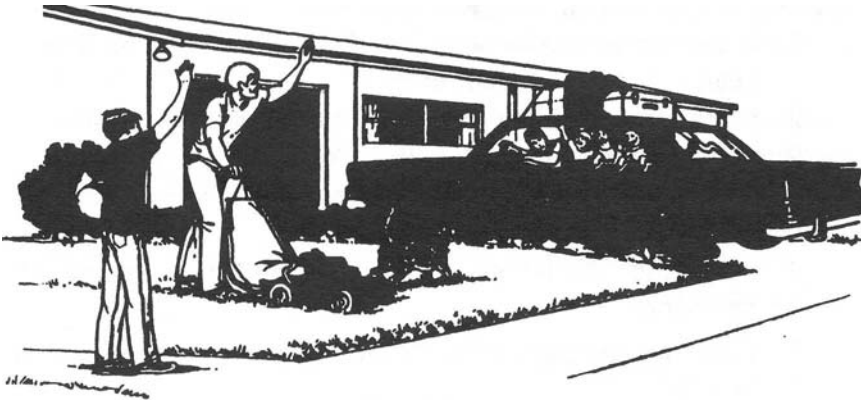

When going on vacation or out-of-town for any reason:

- Don't publicize vacations ahead of time. Burglars watch for newspaper accounts.
- Notify the police of your plans. They will keep an eye on your house when they are in the neighborhood.
- Stop deliveries of mail and newspapers or ask a friend to pick them up while you are gone.
- Arrange to have the lawn mowed.
- Leave information on where you can be contacted in an emergency with a trusted neighbor and ask them to keep an eye on the house.
- Give your house a lived-in appearance. A residence that presents a lived-in appearance is a deterrent to burglars.
- Have a neighbor occasionally use your garbage can.
- Put automatic timers on several lights and a radio. Set them so they will turn on and off at random times in different rooms especially the bathroom.
- Don't leave lights on 24 hours a day.
- Leave drapes in a normal position to maintain a lived-in appearance.
- Turn the bell on the telephone down to low.
- Have a neighbor park in your driveway or in front of your house

SECURING YOUR APARTMENT

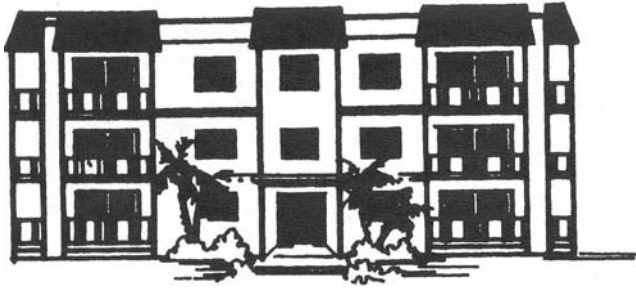

- All exterior doors should be checked for adequate security.
- When moving into a new apartment, have all locks rekeyed. This can be done by a licensed locksmith and is relatively inexpensive.
- Deadbolt locks should be installed on all exterior doors. The tenant usually absorbs the cost. If possible, do not master key these locks to management locks because master keying defeats the security of a lock. The manager of the building can be given a key in a sealed envelope to be used for emergencies only, not for things such as repairs, exterminators, etc.
- Properly secure all sliding glass doors and windows, regardless of what floor you live on
- Get your neighbors together to demand adequate lighting in stairwells, parking lots, courtyards, laundry rooms and the exterior of the building.
- Insist that shrubs be cut back so they don't offer concealment for a burglar.
- Don't advertise that you are a woman living alone. Use your first initial only on the mailbox and for telephone listings
- If you are planning to be away for an extended period, inform the office of your plans and where you can be reached. Be sure to stop all deliveries.
- Lock up even when at the pool, game room or neighbor's for a few minutes
- Be cautious of door-to-door salesmen or someone who wants to give you something for free.

SECURING YOUR MOBILE HOME

Because of their basic construction, some older mobile homes are more difficult to secure than a permanently-found ed structure. Recent federal regulations have brought construction of mobile homes closer to the standards for conventional housing.



- Special care should be used when securing all doors and Windows to the specifications already given in this booklet.
- Door hinges should be properly pinned since doors on mobile homes are generally not of solid core construction (See section on Hinge Doors in chapter on Closing Your Doors to Burglary)
- Before installing an auxiliary dead bolt lock on your mobile home door, check first to see if the door needs reinforcing. When installing a lock on a properly reinforced door, you should also secure the metal framing around the strike plate by installing screws over and under the strike to make sure the metal frame cannot be tampered with.
- Jalousie doors on a mobile home present .the same security problem as they do on standard homes. They should be replaced with solid wood core doors, or the inside of the door can be covered with heavy gauge expanded metal mesh, through-bolted to the door with carriage bolts
- Consider some kind of an intrusion detection alarm system. (See chapter on Burglary Alarm Systems) At least consider installing individual door alarms, which are relatively inexpensive, on each exterior door.
- Consider installing an early warning fire alarm system. This is particularly important in a mobile home.
- If you have a utility shed, reinforce the inside of its door with plywood running the whole length of the door. Then attach a case hardened steel hasp to the door, through-bolted with carriage or stove bolts, and secure it with a good quality pad-lock. (See chapter on Padlocks and Hasps)
- Consider establishing a neighborhood awareness program in your mobile home community. This is an excellent deterrent to burglary. (See chapter on The Neighborhood Awareness Concept)

THE NEIGHBORHOOD AWARENESS CONCEPT



Citizen participation is one of the most effective tools against crime because the job of stopping burglary, robbery or sexual assault is impossible for the police to accomplish alone. Crime watchers are networks of neighbors trained by crime prevention officers in home and self-protection, suspect identification and how to serve effectively as additional eyes and ears for law enforcement agencies in their communities.

Neighborhood awareness or crime watcher groups provide a way for neighbors to help one another by keeping an eye on each other's homes and property. A telephone chain is set up to enable neighbors to keep one another informed of any criminal activity and to receive information from the police concerning descriptions of suspected criminals and other pertinent information.

When a member of a network sees a suspicious person or vehicle, one that meets the description given through the telephone chain, or a crime in progress, they call the police "Hot line" to report.

You should **never** attempt to apprehend a suspect. This is the law enforcement officer's job.

It is recommended, too, that members of a network have a handy listing of immediate neighbors' names, addresses and phone numbers and business phone numbers.

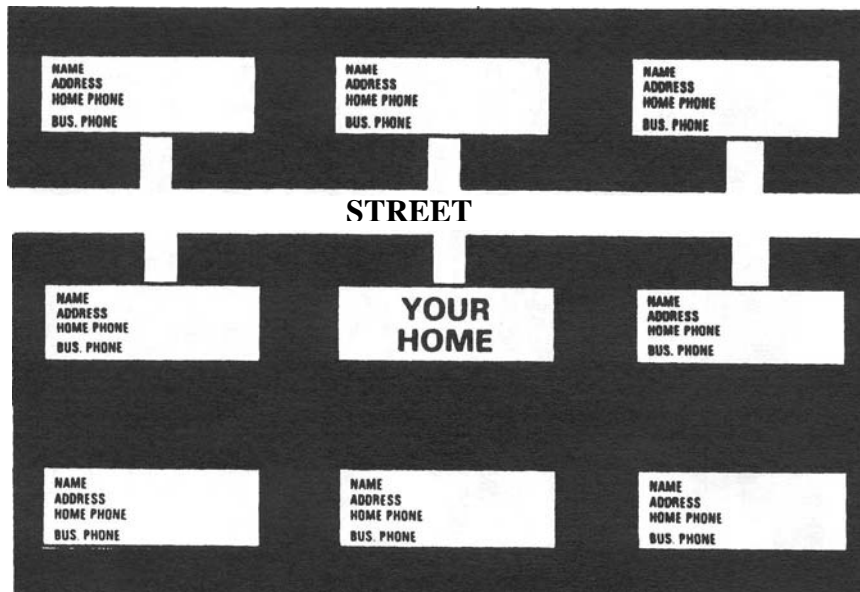

Do not reveal your name, phone number, address or other personal information to unknown callers. Don't tell a stranger that your neighbor is not at home. Never give out information that you are alone or when you will be away. Instruct children to do the same when answering the phone.

SUSPECT IDENTIFICATION CHART

19.

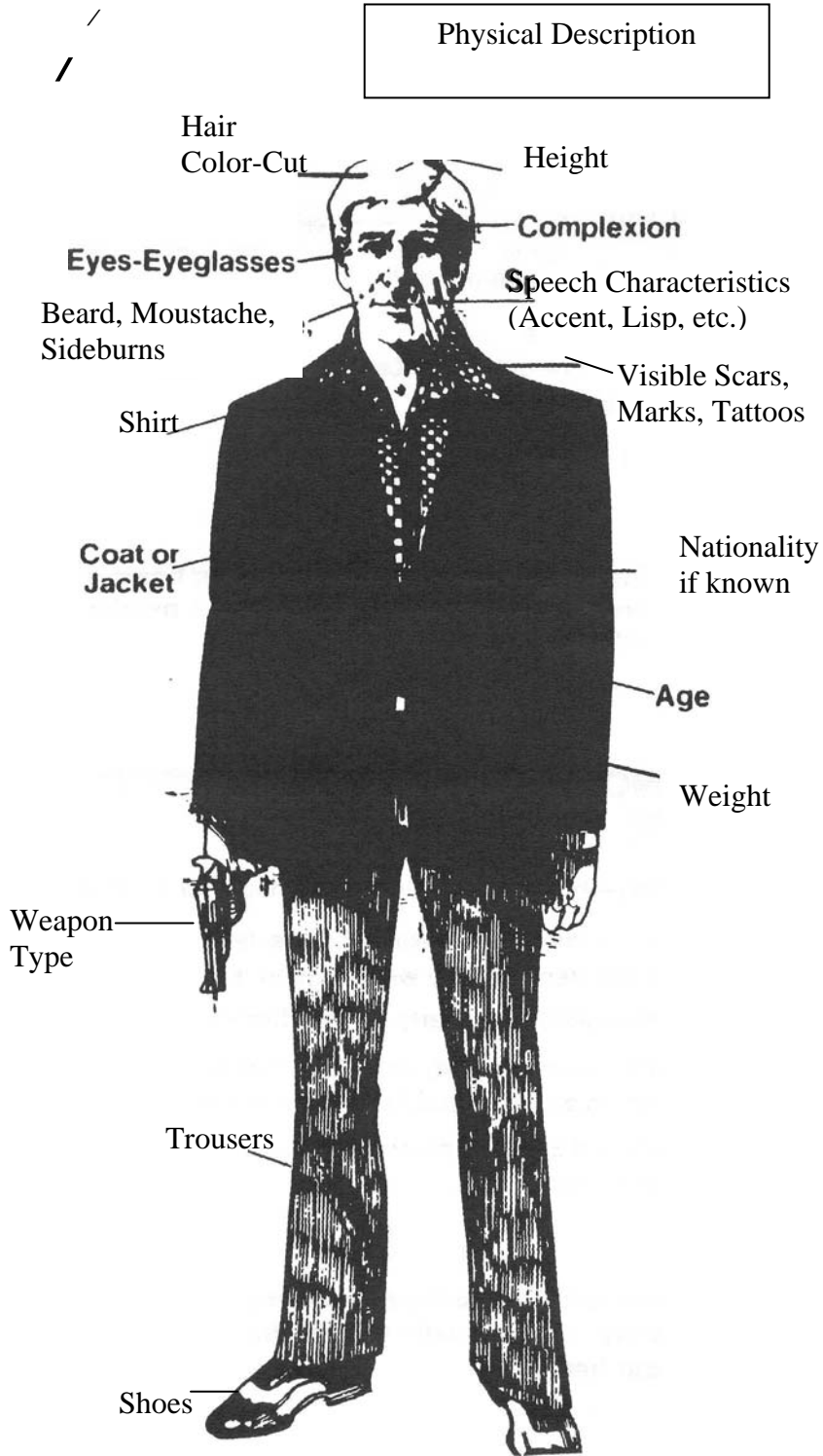

VEHICLE DESCRIPTION REPORTING

In reporting the description of a suspicious vehicle in your neighborhood to the police, try to supply the following information:

1. Color
 - a. vinyl top, convertible
 - b. give top color first (black over white, etc.)
2. Size: large, medium or small
3. Identifying marks.
 - a. tag number - entire number or first three digits is helpful
 - b. dents broken glass
4. Direction of travel

If you hear or suspect a burglar is in your home while you are there, avoid a confrontation. If a phone is nearby, call the police immediately.

TERMINOLOGY WHEN REPORTING CRIMES

- Burglary-breaking and entering a house or other structure
- Robbery-(armed) the taking of some item(s) while a person is being threatened with a weapon (gun, knife, club, etc.)
- Larceny-theft of property without forced entry
- Assault-an intentional, unlawful threat by word 'or act to do violence to a person, coupled with an apparent ability to do so
- Assault and Battery-physical' assault of a person without the use of a weapon

If someone comes to the door asking to use the phone for an emergency, offer to make the call for them-but don't let them in your house.

PROCEDURE FOR REPORTING TO POLICE

When reporting a crime, give police this information:

1. Identify yourself-name, address, phone number
2. Type of crime (burglary, assault, suspicious person or vehicle, etc.)
3. Crime "in progress" or "has occurred"
4. Where? Be as specific as possible.
5. Description of suspect, whether armed, how many
6. Description of vehicle, tag number.
7. Direction of travel

The more information you can give the police the better.

If you come home to find you have been burglarized, do not enter your house or apartment. Immediately find a phone and call the police. Wait at a neighbor's home until they arrive.

COMMUNITY SERVICES - The following programs are available to individual citizens or groups of citizens living in West Palm Beach. Clubs, civic associations, churches, fraternal organizations, schools, etc. are eligible for these group presentations.

Residential Burglary Seminars - How to safeguard your home and personal property.

Business Security Surveys - Receive a complete analysis of your business. Trained police - personnel will survey your business and point out vulnerable areas and recommend improvements .

. * * * * *

Sexual Assault Seminars - Women learn how to avoid rape, assault, criminal confrontation; victims receive counseling, and assistance.

* * * * *

Crimes Against the Elderly - For groups or individuals. Shows vulnerability, how to prevent the crimes.

Law Enforcement of Tomorrow - Cadet and Explorer Program for Youth (Ages 14 - 21) interested in a Law Enforcement Career.

* * * * *

Commercial Armed Robbery Seminars - Armed robbery prevention what to do when the robber comes.

GET INVOLVED I

DO IT TODAY - JOIN THE FASTEST GROWING ORGANIZATION OF CONCERNED CITIZENS IN WEST PALM BEACH

- CALL 822-1620

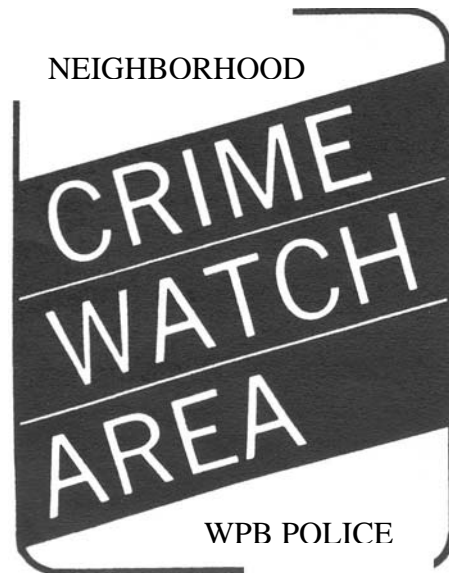

POLICE & CITIZENS

working together to promote a safer community through group action



**FOR EMERGENCIES, DIAL 911
FOR NON-EMERGENCIES 822-1900 WEST
PALM BEACH POLICE DEPARTMENT**

Courtesy of the
West Palm Beach Police
Department

Community Response Division
Crime Prevention Unit
822-1620